



CAR SET-UP FOR EXS 2005

Page 1 / 4

PILOTA \ DRIVER: _____ DATA \ DATE: _____

CIRCUITO \ CIRCUIT: _____

CONDIZIONI PISTA \ TRACK CONDITION: _____

TEMPERATURA \ TEMPERATURE: _____

AUTOMODELLO \ CAR : EXS GTS 2005

CARROZZERIA \ BODY SHELL: _____

GOMME \ TYRES: REAR KRONOS 20 \ FRONT KRONOS 27

MOTORE \ MOTOR: _____

SERVOCOMANDI \ SERVOS: _____

RADIO \ TRANSMITTER: _____

CARBURANTE \ FUEL MIX: _____

NOTE: _____

1) FRONT CAMBER STATIC POSITION

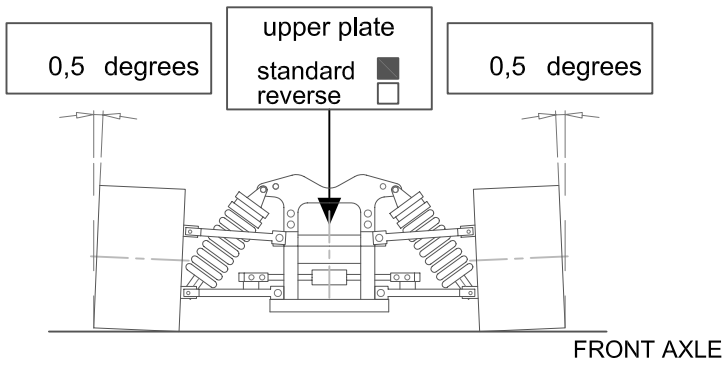

2) DINAMIC REAR CAMBER

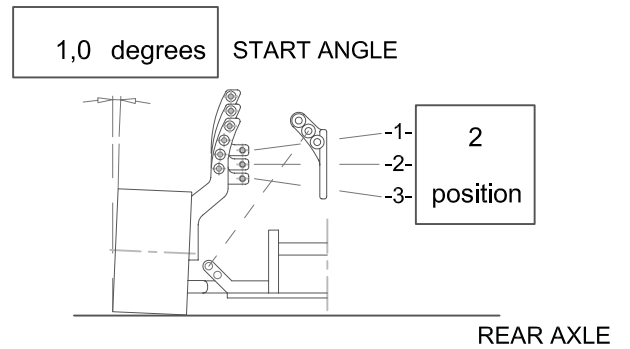

3) TOE OUT - TOE IN

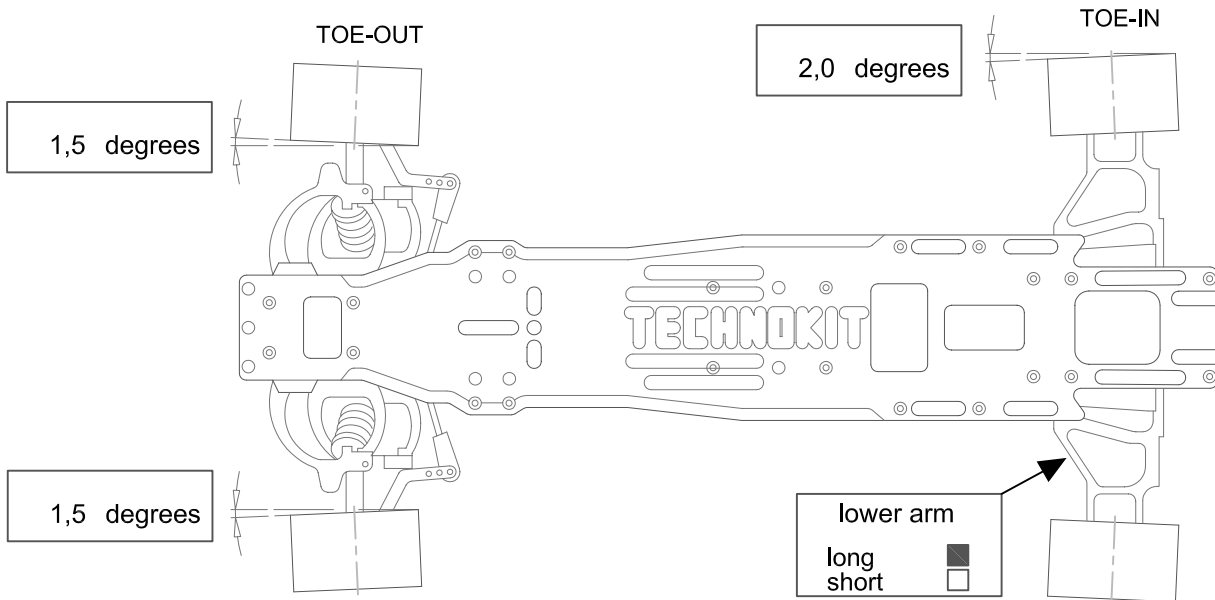

4) DINAMIC FRONT CAMBER

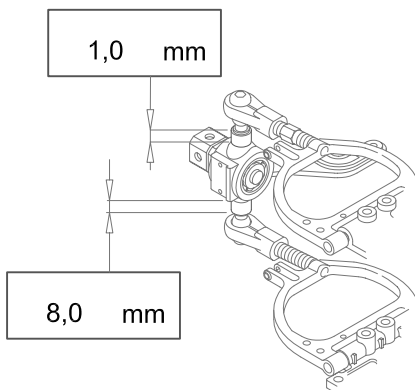

5) HAKERMAN ANGLE

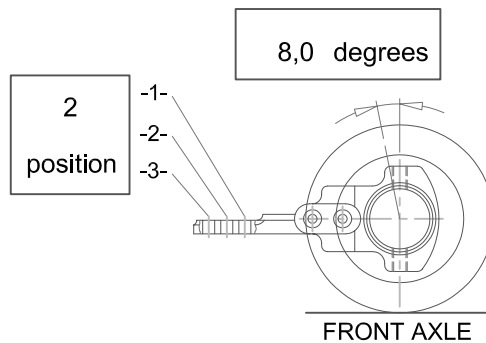

6) SERVO SAVER

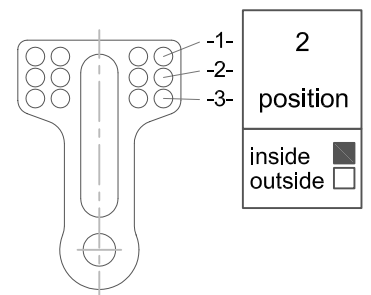

7) REAR ROLL-BAR

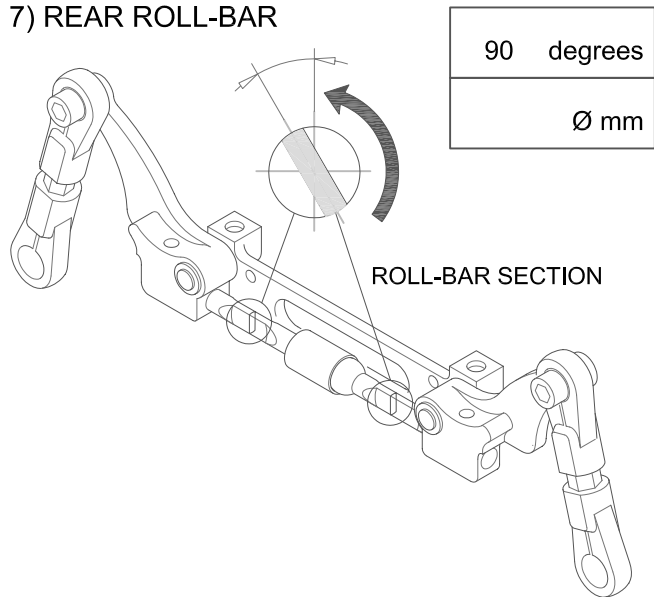

8) FRONT ROLL-BAR

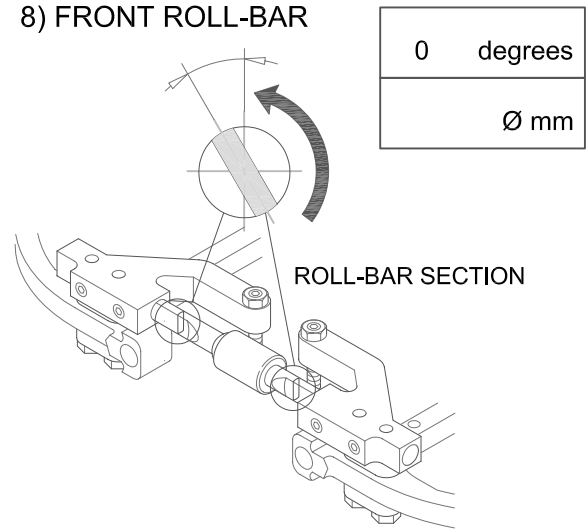

9) REAR SHOCK ABSORBER VR.2004

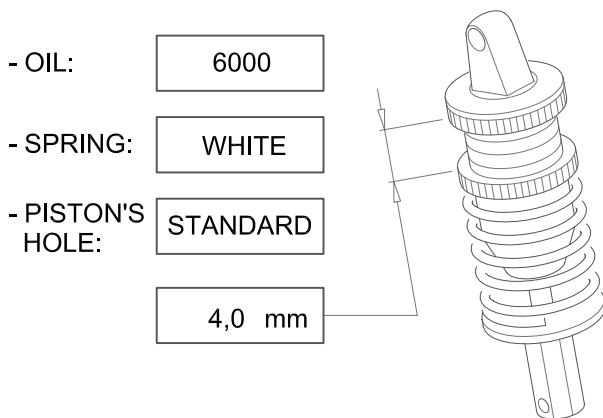

10) FRONT SHOCK ABSORBER VR.2004

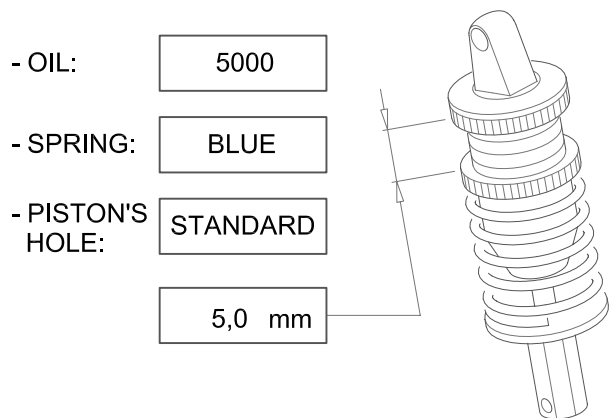

11) MOTOR-WHEELS GEAR RATIO

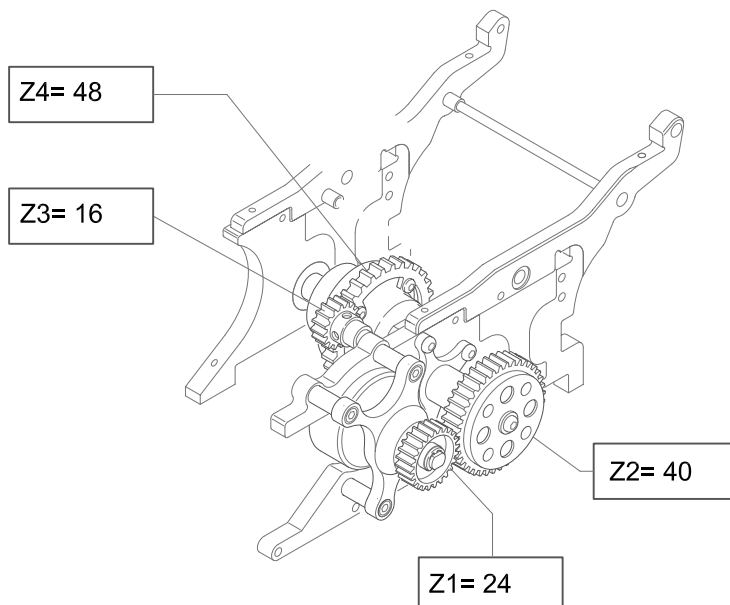

Z1	Z2	Z3	Z4	GEAR RATIO SVILUPPO
23	40	15	48	4.94
24	40	15	48	4.87
25	40	15	48	4.80
23	40	16	48	4.74
24	40	16	48	4.67
25	40	16	48	4.60

12) DIFFERENTIAL

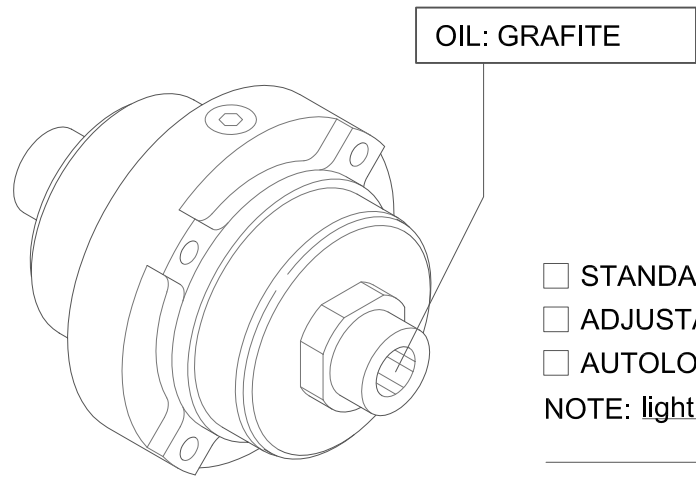

- STANDARD
- ADJUSTABLE
- AUTOLOCK

NOTE: light case _____

13) BASE CHASSIS STATIC POSITION

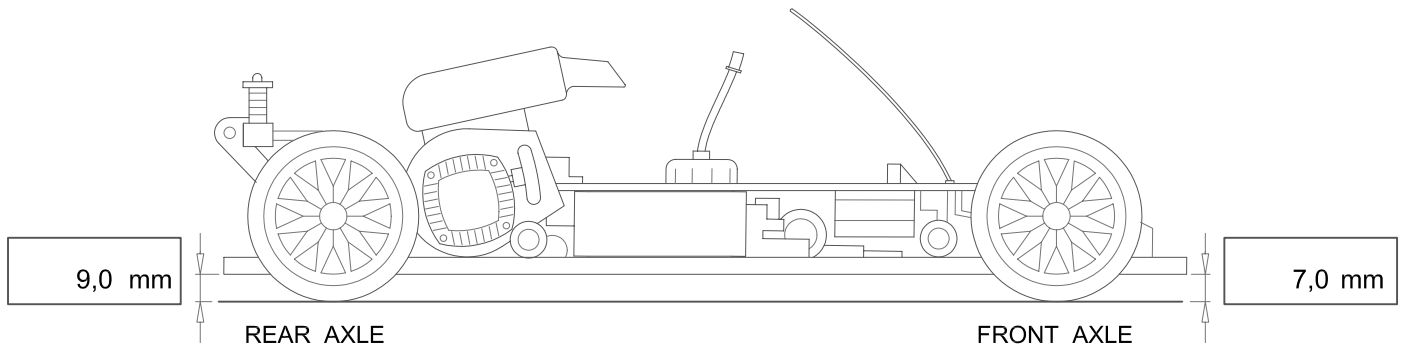

14) REAR RANGE MAX.

15) FRONT RANGE MAX.

